



# Portable Freezer & Combined Refrigerator-Freezer

## ETS Compressor Portable Freezer (DC)



VF PF-12DC

VF PF-35DC

These portable freezers are lightweight. They double as great bar fridge, or an extra cooler to frozen or chilled keep samples/specimens/plasma in the vehicle while you are on the go. The entire portable freezers are built using an impact resistant polypropylene exterior that offers outstanding protection. Simply set the temperature and the electronic temperature controller does the rest.

## ETS Combined Refrigerator/Freezer (DC)

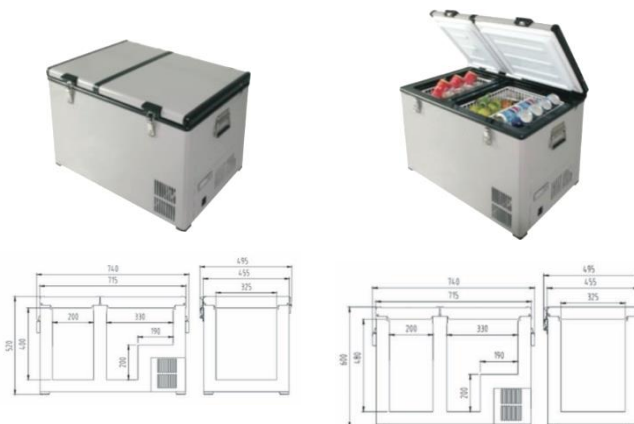

VF PF-60DC

VF PF-80DC

The Combined Refrigerator/Freezers are in a league of their own. With two independently controlled compartments, the configuration is up to you. Choose from the typical setup of fridge/freezer, or set both compartments at the same temperature to create a larger refrigerator or freezer.

Model	VF PF-12DC	VF PF-35DC	VF PF-60DC	VF PF-80DC
Dim. Ext (mm) W x D x H	190 x 505 x 385	355 x 630 x 415	740 x 495 x 520	740 x 495 x 600
Dim. Int (mm) W x D x H	125 x 370 x 300	250 x 496.5 x 303.5	200 x 325 x 400 / 330 x 325 x 400	200 x 325 x 480 / 330 x 325 x 480
Capacity	15L	35L	60L	80L
Internal Chamber	ABS			
External Chamber	Epoxy Coated Mild Steel			
Temperature Control / Range	LED Digital Display / +10°C to -22°C			
Temperature Fluctuation	±1.0°C			
Internal Cooling System	Direct Cooling Wall			
Refrigerant	R134a CFC-free			
Power Voltage	12VAC/DC or 24VAC/DC			
Display	Digital (use DC battery)			
Net Weight (KG)	8	16	29	31.5
Hold Temperature w/o DC supply at +2°C to +8°C	Up to 3 to 4 hours			
Safety Features & Certification	ISO 13485, Electric Safety Test (EST) IEC 61010-1 (2010), GDPMD, ISO IEC 17025			

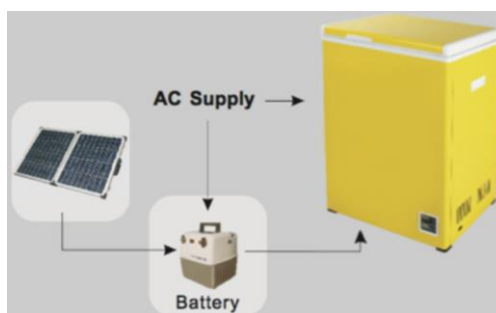

### Features:

- ✓ Environmental friendly – rechargeable by solar power
- ✓ Convenient